

Delta 4 AHU Technical Information

Specialist Design, Support and H & V
solutions for all wet leisure projects



Solutions for:

- Humidity control
- Pool water heating
- Ventilation
- Air cooling
- Recovering energy
- Air heating

Specification - Model Delta 4 - General

Supply one specifically designed swimming pool heat recovery and dehumidification unit as follows: -

Unit comprising: -

- Galvanised and plastisol coated insulated steel cabinet, panels with quick release fasteners, mounted on a hot dip galvanized chassis.
- Variable speed EC main recirculation fan.
- Variable speed EC exhaust air fan.
- Filters for recirculation and fresh air inlets.
- Fresh air louvre dampers driven by a controlled positioning motor, for automatically regulated introduction of fresh air, set to provide pool hall negative pressure.
- Heat pump dehumidifier for the recirculation and exhaust airflows incorporating heat recovery to pool water and pool hall air.
- Fully controlled LPHW air heater battery.
- Fully controlled LPHW pool water calorifier.
- Integral control panel complete with sensors and controllers for:
 - Humidity
 - Air temperature
 - Pool water temperature
 - Comprehensive running and fault indicators
 - Network Connection via RJ45 interface
- Optional features

Specification - Model Delta 4 - Detail

Chassis and Cabinet

The chassis shall be fabricated from cold rolled mild steel section hot dip galvanized. The cabinet shall be formed from galvanised and plastisol coated steel sheet and insulated internally with expanded P.V.C. foam sheet, type 3509, having density of 260 kg/m³ and thermal conductivity K = 0.043 W/mK.

The unit shall be totally insulated and panels shall be removable for service and for access to fresh air and recirculation filters. Panels shall be manufactured from galvanised steel sheet with outer sides having plastisol coating, Leathergrain finish. Service panels shall have quick release fasteners.

The whole construction of the unit shall be designed to withstand the corrosive atmosphere normally experienced in a swimming pool building. A compact solution, the unit shall come as one piece, overall size 1840mm long x 704mm wide x 1960mm high

Main Recirculation Fan

The main recirculation fan shall be capable of circulating 3,000 m³/h (0.83 m³/s) pool hall air against an external total pressure loss of 70mm wg (700Pa). It shall be driven by an electrically commutated direct drive motor. On single phase machines the motor shall be protected by a motor rated MCB. On three phase machines the motor shall be protected by a 3 phase motor start circuit breaker.

Exhaust Air Fan

The exhaust air fan shall be capable of exhausting up to 1,500 m³/h (0.42 m³/s) used air against an external total pressure loss of 28mm wg (280Pa). It shall be driven by an electrically commutated direct drive motor. On single phase machines the motor shall be protected by a motor rated MCB. On three phase machines the motor shall be protected by a 3 phase motor start circuit breaker.

Air Filters

The unit shall be complete with recirculation and fresh air filters which shall be easily changed. The filters shall be 50mm deep disposable panel filters, bonded glass fibre type with an EN 779 classification of G2.

Exhaust/Fresh Air Dampers

Exhaust air delivered by the exhaust fan to atmosphere shall be quantitatively varied by the exhaust fan. Fresh air shall be varied by an air inlet damper, driven by a dedicated multi-position control motor. The dampers shall be galvanised geared units of high quality construction and shall be set such that the pool hall is maintained under negative pressure.

Signal for the control motor shall be provided from the integral control panel. The exhaust air volume shall be automatically modulated by the control system from a minimum flow of 150m³/h up to a maximum of 1,500 m³/h, which shall be influenced by the following parameters:-

- The pool hall humidity
- The pool hall temperature
- The external ambient temperature
- The air quality sensor (if fitted) detecting deterioration of the pool hall air condition

Heat Recovery Heat Pump Dehumidifier

The heat pump shall be capable of acting as a heat recovery dehumidifier from the recirculating and exhaust air when required, and as a refrigerated air conditioning unit when the pool air conditions rise above the pool hall temperature set point. It shall be automatically controlled from the integral control panel.

It shall have a net heat recovery capacity of 7.4kW at pool conditions of 28°C and 60%RH. During heat recovery the energy shall be capable of being fed into the pool water and/or air. During air conditioning, the recovery energy shall be automatically directed to the pool water and/or rejected at the exhaust air condenser whichever is appropriate.

Evaporators and air condensers shall be of copper tube with aluminium fins protected by high integrity polyester coating. Pool water condenser shall be a seamless tube-in-tube coaxial unit manufactured from extended surface 90/10 cupro-nickel where in contact with the pool water.

Auxiliary air heating

An LPHW air heater battery with fully controlled valve shall be provided, rated at 25kW, to provide heat to the air stream, with 21.8kW available for building fabric losses with fresh air at -5°C. The heat output shall be rated with LPHW supplied from an external source at a flow temperature of 80°C. The heater battery shall be of copper tube with aluminium fins protected by high integrity polyester coating.

Auxiliary pool water heating

An LPHW pool water calorifier with fully controlled valve shall be provided, rated at 33kW, to provide top up heat to the pool water to make up unrecoverable losses. The heat output shall be rated with LPHW supplied from an external source at a flow temperature of 80°C. The heat exchanger shall be manufactured from 316 stainless steel.

Specification - Model Delta 4 - Controls

The control panel shall be integral with the unit and all necessary sensors, controllers, motor starters, overloads and circuit breakers shall be integrated within the cabinet. The unit shall control the following parameters:-

- Humidity 2 stages
- Air temperature 3 stages (including unoccupied set-back)
- Pool water temperature 2 stages

Control of humidity, air temperature and water temperature shall be by PLC digital controllers which shall provide displays of actual and set point readings. An integral time clock shall be provided to work in conjunction with the third air temperature stage to cater for unoccupied air temperature set back for energy economy, if a pool cover is used.

A 2-position ON-OFF function shall be provided on the control panel.

A 2-position WATER-AIR function shall be provided on the control panel to override heat recovery priority.

A 2-position ENABLE-DISABLE function shall be provided on the control panel to allow manual override of air conditioning operation.

A 3-position MAX-AUTO-MIN switch shall be provided on the control panel to allow manual override of fresh air operation.

Warning indicators shall be provided on the display screen to indicate the following conditions:-

- Mains ON
- Compressor Fault
- Compressor Defrost
- Fresh air operation Auto

Indicators shall be provided on the display screen to indicate when the machine is providing:-

- Dehumidification by heat pump
- Air heating via LPHW
- Air cooling by heat pump
- Water heating via LPHW

The following remote contacts shall be available at the main terminal block to provide the following control interfaces: -

- Indication of auxiliary water heater or air heater in operation, requiring LPHW to be supplied (volt-free contacts) - can control a dedicated boiler to switch ON or OFF as determined by machine or to control a 3 port bypass valve if required.
- Indication that pool pump is required to run (12V supplied from machine) - can control a dedicated pool water pump to come on only when required for heat recovery to pool water or auxiliary water heating.

- Remote override of occupied/unoccupied mode (12V supplied from machine) - can override the integral time clock to put the control system into occupied mode when pool is uncovered.

The following volt-free pairs shall be available at the auxiliary terminal block situated on top of the cabinet to provide remote indication of:-

- Machine on
- Main fan running
- Exhaust fan running
- Compressor running
- Compressor fault

An ambient air temperature control shall be provided in the fresh air inlet to control reduction of fresh air quantity in cold weather at an adjustable threshold.

An air temperature control shall be provided to maintain the unoccupied air temperature.

A pool water pressure switch shall be provided to detect loss of pool water flow.

A flow meter shall be provided to indicate the pool water flow through the heat recovery condenser and LPHW to the pool water calorifier.

Optional features

The following optional features shall be available on request: -

- Air differential pressure switches can be fitted across main and/or exhaust fans to detect fan pressure and provide a fan failure signal.
- Air differential pressure switches can be fitted across recirculation filters to detect the filter pressure drop and provide a filter dirty signal.
- An air quality monitor can be provided to detect deterioration in pool hall air condition and force the maximum quantity of fresh air to be introduced.
- The LPHW air heater battery can be upgraded to compensate for lower LPHW flow temperatures.
- The LPHW air heater battery can be provided with frost protection to force the minimum quantity of fresh air to be introduced.
- The air temperature and humidity sensors can be fitted in a remote sensor enclosure to provide remote measuring of pool hall relative humidity and air temperature.
- The compressor can be fitted with a soft-start.

DELTA MODEL 4

SINGLE LPHW/BOILER WATER IN 28mm COPPER STUBS
 SINGLE LPHW/BOILER WATER OUT 28mm COPPER STUBS
 DOUBLE LPHW/BOILER WATER IN 35mm COPPER STUBS
 DOUBLE LPHW/BOILER WATER OUT 35mm COPPER STUBS

POOL WATER OUT 1" PVC STUB
 POOL WATER IN 1" PVC STUB

DRAIN 3/4" BSPM STUB

* SEE DUCT DIMENSION DATA

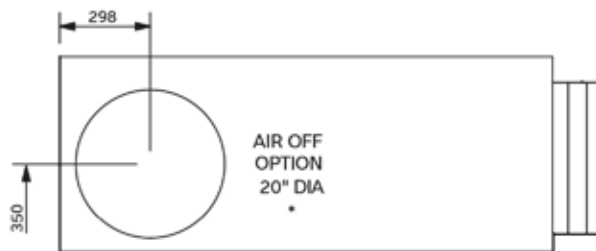
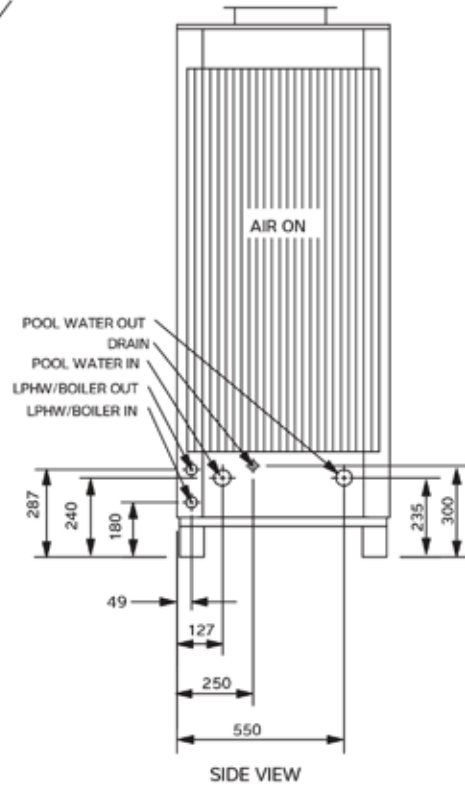
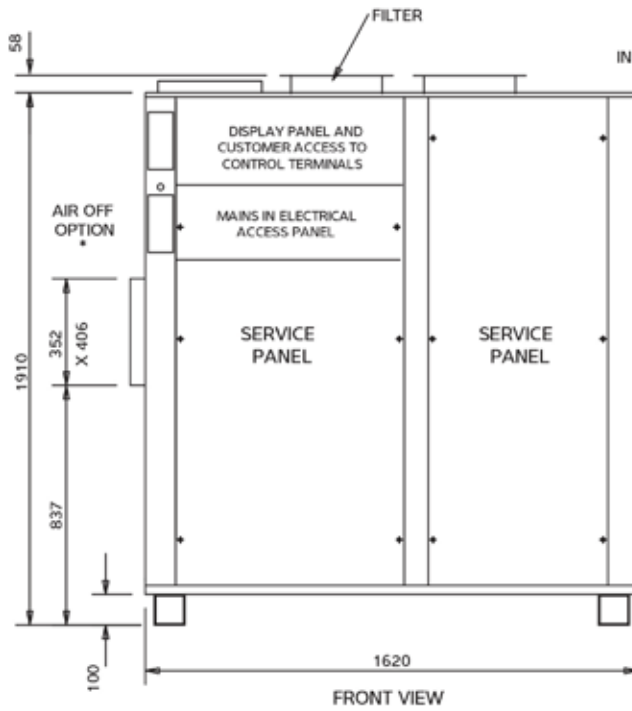
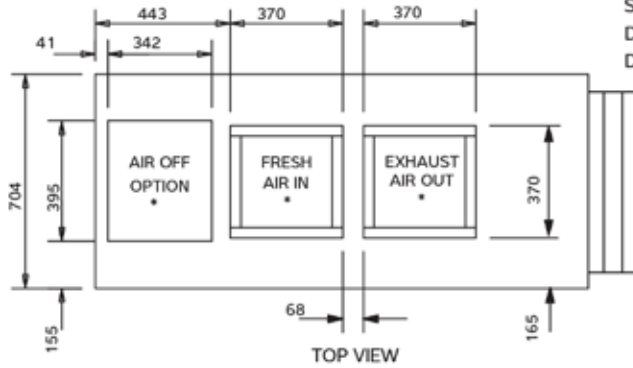

DELTA MODEL 4

(OPPOSITE HAND)

SINGLE LPHW/BOILER WATER IN 28mm COPPER STUBS
 SINGLE LPHW/BOILER WATER OUT 28mm COPPER STUBS
 DOUBLE LPHW/BOILER WATER IN 35mm COPPER STUBS
 DOUBLE LPHW/BOILER WATER OUT 35mm COPPER STUBS

POOL WATER IN 1" PVC STUB
 POOL WATER OUT 1" PVC STUB
 DRAIN 3/4" BSPM STUB

* SEE DUCT DIMENSION DATA

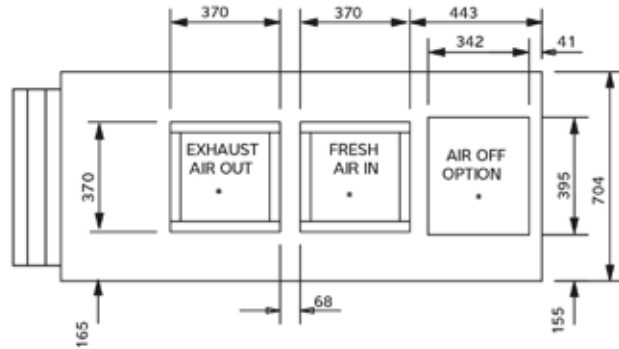

TOP VIEW

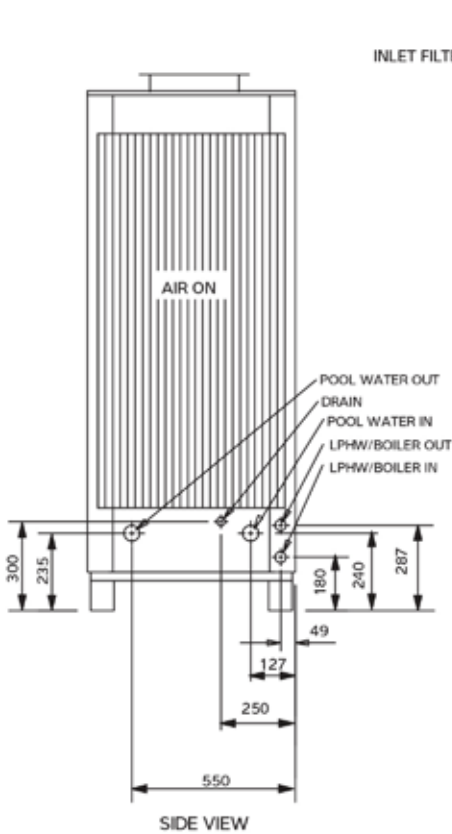

SIDE VIEW

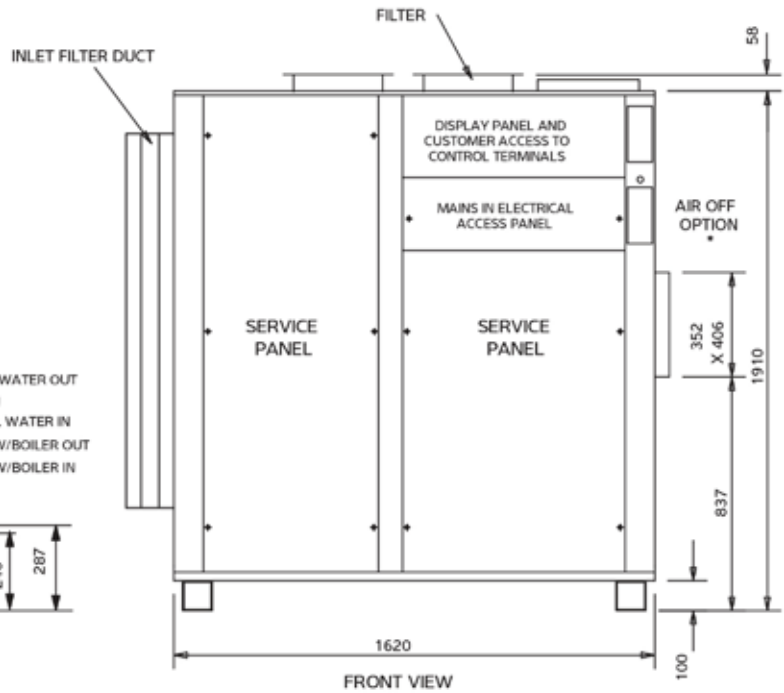

FRONT VIEW

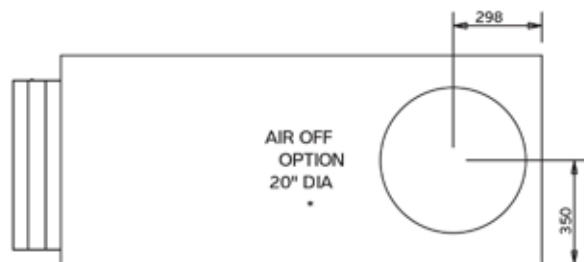

DELTA 4 DUCT DIMENSION DATA

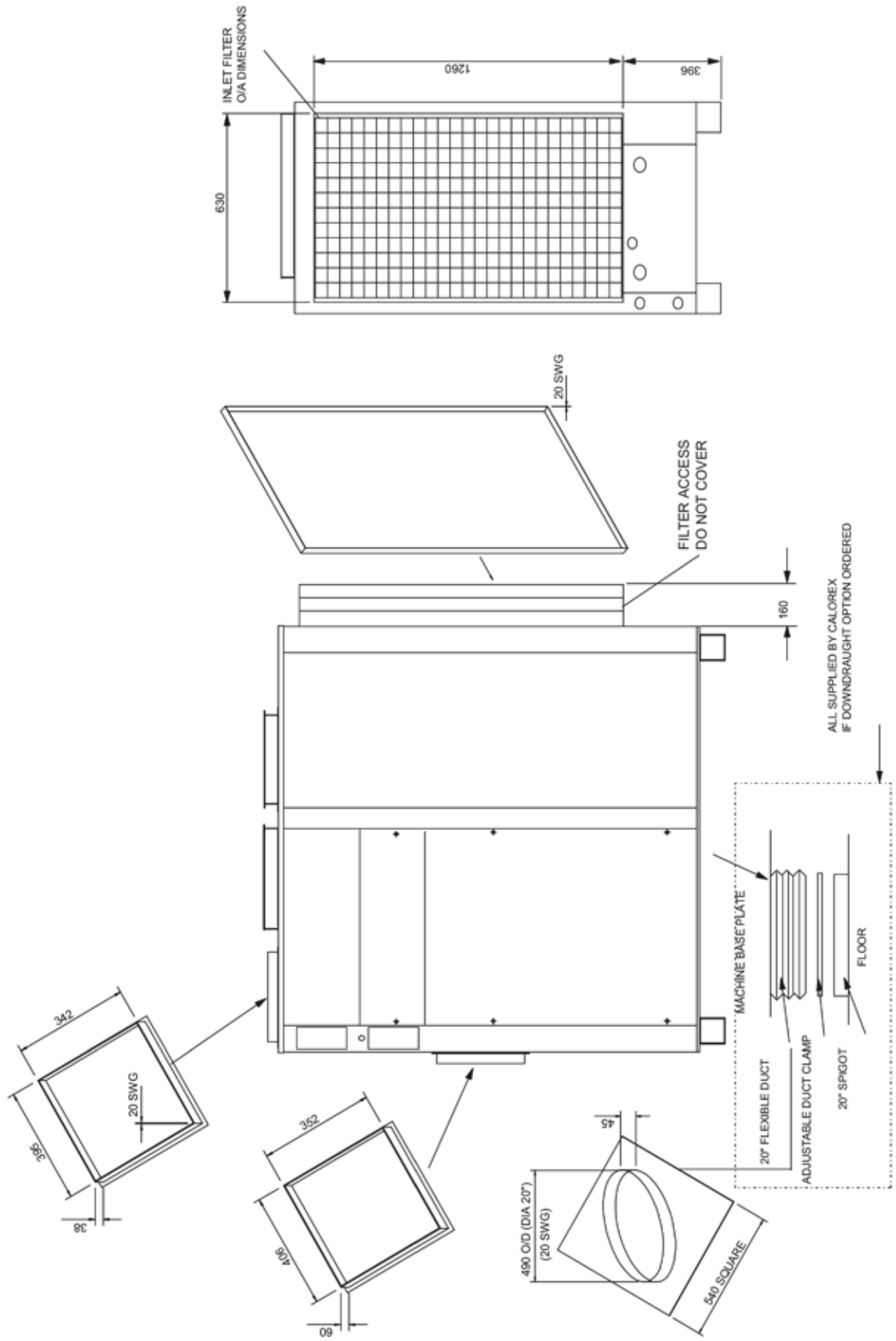

Data Sheet - Delta 4

Dehumidification Duty Via Heat Pump (28°C / 60%rh) (Dampers Min) l/hr 6 Total @ 18°C Dewpoint (Summer) (Damper Max) l/hr 9 Total @ 7°C Dewpoint (Winter) (Damper Mid) l/hr 12.1 VDI 2089 l/hr 9.5 Total DH + VDI 2089 @ 12.5°C Dewpoint (Summer) l/hr 12.5	Electrical Total Power Consumed (Nominal) kW 2.9 Min Supply Capacity (Max FLA) 1ph N amps 25 Min Supply Capacity (Max FLA) 3ph N amps 13 Max Supply Fuse 1ph N amps 40 Max Supply Fuse 3ph N amps 20
Heat To Air Via Heat Pump (Mode A) kW 1.4 Via Heat Pump (Mode B) kW 5.1 Via LPHW @ 80°C kW 25 Total kW 26.4/30.1 Via Double LPHW kW 42.5	Main Fan - Variable Speed Air Flow m ³ /hr 3000 Max Internal Static Pressure mmWg 70 FLA 1ph N amps 6.8 FLA 3ph N amps 4
Building Heat Loss Heat Required For Fresh Air @ -5°C kW 8.3 Available For Fabric Losses @ -5°C kW 21.8	Exhaust Fan - Variable Speed Air Flow (Summer) m ³ /hr 1500 Air Flow (Winter) m ³ /hr 750 Air Flow (Unoccupied) m ³ /hr 150 Max External Static Pressure mmWg 28 FLA 1ph N amps 3
Heat To Pool Water Via Heat Pump (Mode A) kW 5.8 Via Heat Pump (Mode B) kW 2.3 Via LPHW @ 80°C kW 33 Total kW 38.8/35.3 Flow Rate Pool Water ± 10% l/min 38 Pressure Drop @ Rated Flow m/hd 2.5 Max Working Pressure bar 3.5 Internal Condenser Taco Pool Water Setting l/min 24	Compressor Nominal Power Consumed kW/hr 2.1 LRA 1ph N amps 62 RLA 1ph N amps 12.4 Soft Start Amps 1ph N amps 28 LRA 3ph N amps 42 RLA 3ph N amps 3.8 Soft Start Amps 3ph N amps 16
Cooling Duty Cooling Duty (Sensitive) mode A/B kW - 2.94 Cooling Duty (Total) mode A/B kW - 4.2	General Data - Hermetic System Gas Charge (R407c) kg 6 Weight Approximately kg 350 Specific Fan Power - 1.01
Recommended Boiler Capacity Flowrate l/min 35 Flow Rate - Double Coil l/min 50 Pressure Drop @ Rated Flow m/hd 2.5 Max System Working Pressure bar 6	

For accurate application sizing please consult Calorex Heat Pumps Ltd

Mode A = recovered heat biased to pool water (Pool water temp not satisfied)

Mode B = recovered heat biased to pool hall air (pool water temp satisfied)

R407c Global Warming Potential (GWP) 1774

1mm WG = 9.8 Pa

1m hd = 1.4 psi

1l/min = 0.22 gal/min

Warranty Conditions

The following exclusion apply to the Warranty given by Calorex Heat Pumps Ltd

No claims will be accepted if:

1. The Heat Pump is incorrectly sized for the application
2. The Heat Pump is installed in any way that is not in accordance with the current procedures as defined by Calorex Heat Pumps Ltd
3. The Heat Pump has been worked upon or is adjusted by anyone other than a person authorised to do so by Calorex Heat Pumps Ltd
4. The air flow to and from the machine is outside the specified limits
5. The water flow through the machine is outside the specified limits
6. The water pH level and / or chemical balance is outside the following limits

Acidity	pH	7.2-7.8
Total Alkalinity as CaCO ₃	ppm	80-120
Total Hardness as CaCO ₃	ppm	150-250
Total Dissolved Solids	ppm	1000
Maximum Salt Content	ppm	8000
Free Chlorine Range	ppm	1-2 Domestic
Free Chlorine Range	ppm	3-6 Commercial
Superchlorination	max	30ppm for 24 hours
Bromine	ppm	2-5
Baquacil	ppm	25-50
Ozone	ppm	0.9 Max
Max Copper Content	ppm	1
Aquamatic Ionic Purifier	ppm	2 Max
7. The Heat Pump has suffered frost damage
8. The electrical supply is insufficient or in any way incorrect
9. The fan amps and duct pressure are outside the specified limits
10. The Heat Pump must be maintained in accordance with service requirements in section 2.6.
For details of the extended warranty and maintenance packages please call H & V Divison.



Office Use Only:	
Order No:	
Part No:	
Price	
Carriage	

Order Confirmation Form For A Delta

Many thanks for your valued order for a Delta Swimming Pool Control Unit

Please specify configuration required below then confirm it is correct by signing and returning to us on

Fax number 01993 778869

To:	From:
Company:	Date:
Fax:	Ref:

Delta Model	(* available only in 3ph)	Standard - Available in all models	Mirrored - Available in models 4-16				
1							
2							
4							
6							
8 *							
10 *							
12 *							
14 *							
16 *							
Single Phase	Y / N	Three Phase	Y / N	Air Off:	Top	End	Bottom

If the above does not correspond to your requirements please contact Certikin H & V Department to discuss options, alternatively, please liaise with your local distributor.

I confirm the above Delta configuration and specifications meet my requirements and that the unit is non-refundable for reasons of incorrect configuration / specification.

Sign: Print Name: Date:

I would like the Delta to be delivered to site Date:

Please Note: If the unit is in stock for more than 14 days after the above date, an invoice for 50% of the order total will be issued. The balance will be invoiced after a further 28 days. If no date is specified above, we will consider the site delivery date to be 6 weeks after the date of your purchase order.

Please note that your order will not be processed until we receive signed confirmation. Standard lead time for a Delts 1-12 is approximately 4-5 weeks, the Delta 14-16 lead time is approximately 5-6 weeks, however this is dependant on seasonal demand.



**Certikin International Ltd,
Witan Park, Avenue 2,
Station Lane Industrial Estate, Witney,
Oxfordshire, OX28 4FJ United Kingdom**

**Sales Tel: 01993 778855
Admin Tel: 01993 777200
Website: www.certikin.co.uk
Email: info@certikin.co.uk**